

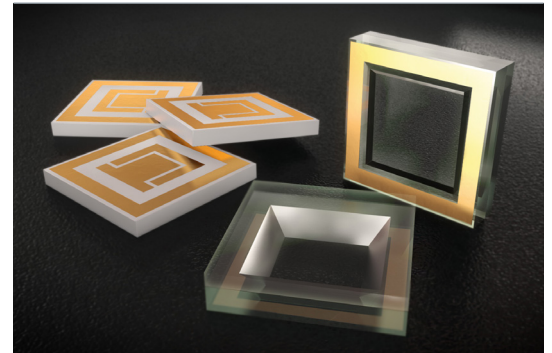

Reflector CupLid – Optical Cavity Window with Al-Reflector

Surface mount Optical Reflector Window for efficient light extraction of edge-emitting Laser Diodes and LEDs in UV, Visible or Infrared

For hermetic packaging of laser diodes and LEDs Materion Balzers Optics has developed Reflector CupLids, a space-saving surface-mount photonic package with integrated mirrors on 45° -angled side-walls. Reflector CupLids form a fine-leak hermetic package by solder bonding a window cavity onto a flat ceramic submount (alumina or AlN) under vacuum or inert gas atmosphere. Reflector CupLids are available with different anti-reflective coatings in UV, Visible or Near Infrared and can be shipped fully-furnished with tack-welded solder preforms for easy handling and assembly. For prototyping we provide several reference designs of AlN submounts for either wirebond or flipchip die-attach.



Benefits

- Space-saving surface-mount photonic package for fully automated die attach and PCB assembly
- Fineleak hermetic package with excellent heat dissipation on AlN ceramic submount
- CupLid cavity window coated with multi-layer anti-reflective coating and Al mirrors on 45° sidewalls
- Fully-furnished packaging solution consisting of CupLid cavity window, AuSn or SnSb solder preform & matching AlN submount

Applications

- Automotive LiDAR systems
- Automotive Laser Head Lights
- Augmented Reality Laser Light Engines
- UV Disinfection / UV Curing
- Lighting Horticulture

Technical Data

Spectral Characteristics AR Coatings

UVC	Rabs < 0.5%, 265 280 nm, AOI<40° Ravg < 0.4%, 265 280 nm, AOI<40°
UVA	Ravg < 0.3%, 325 375 nm, AOI<15°
Broadband	Ravg < 0.3%, 440 650 nm, AOI<15°
Visible AR	Ravg < 0.5%, 440 650 nm, AOI<30° Ravg < 1.0%, 440 650 nm, AOI<45° Ravg < 4.5%, 440 650 nm, AOI<60°
V-Coating (Laser Line)	Rabs < 0.1%, for all common laser lines Rfrom 365 nm–1550 nm

Above spectral specification are for reference only.

MWIR windows available upon request.

Mechanical Dimensions

Window size	Custom sizes available
Window thickness	0.3–1.5 mm
Spacer height	0.3–0.8 mm

Metallization

GeLot™ as adhesion layer and diffusion barrier

Solder Preform on the Lip of the CupLid

AuSn or SnSb solder preform tack welded onto the lip of the CupLid, available on request

Automotive LiDAR

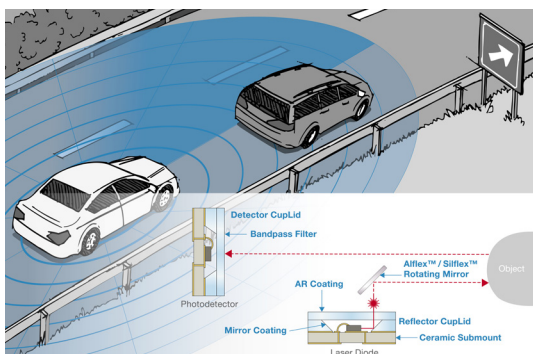

Augmented Reality Smart Glasses

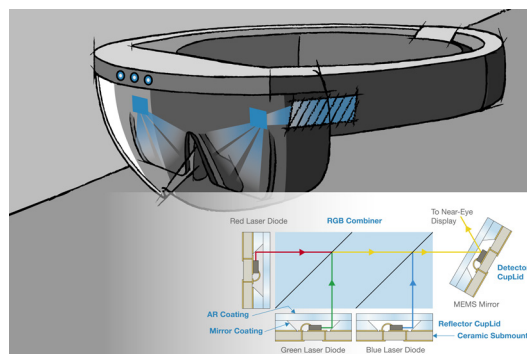

Optics Balzers AG
Neugrüt 35
LI-9496 Balzers

Liechtenstein
T +423 388 9200
F +423 388 9390
info.mbo@materion.com
www.materionbalzersoptics.com

OBA-PE-067 (2107-1)



MATERION

// BALZERS OPTICS

Mechanical Drawing of an Example CupLid

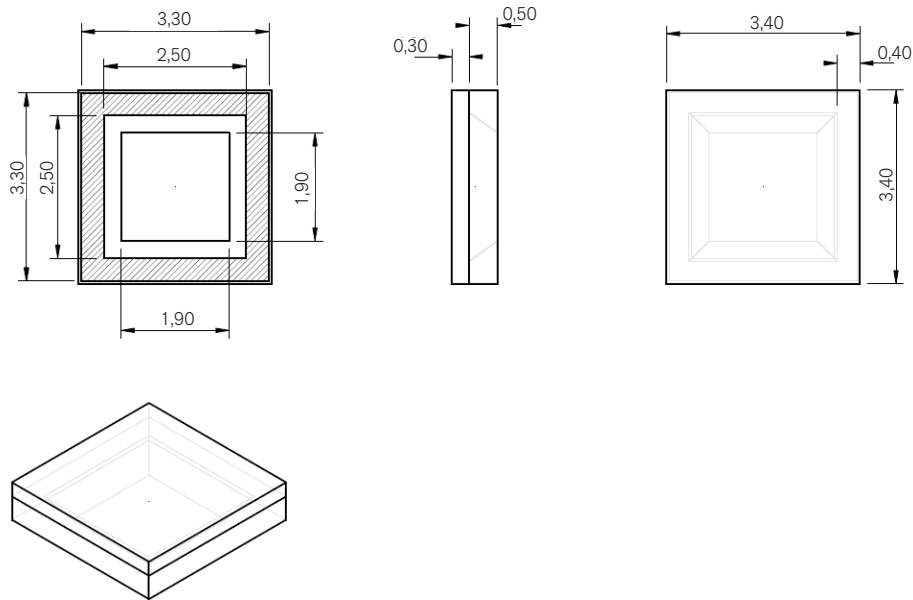

Dimensions in millimeters.
Custom window size available on request. Contact us for design guidelines.

Optics Balzers AG
Neugrüt 35
LI-9496 Balzers

Liechtenstein
T +423 388 9200
F +423 388 9390
info.mbo@materion.com
www.materionbalzersoptics.com

OBA-PE-067 (2107-1)

2/2

Subject to technical change without notice