

Optical and Opto-Mechanical Assemblies

Combined high performance Coatings with Assembly

Materion Balzers Optics seamlessly integrates high performance coatings with advanced assembly techniques. Our unique advantage lies in offering a comprehensive suite of coating and patterning technologies, allowing to tailor solutions for even the most intricate optical assemblies. Our holistic approach combines coatings and assembly under one roof, ensuring optimal compatibility and performance. Our edge-to-edge coatings eliminate shadows and edge effects, enhancing miniaturization for smaller components. Plus, our engineers specialize in designing optical subgroups, maximizing the benefits of our coatings and assembly methods together with our strong network of partners.

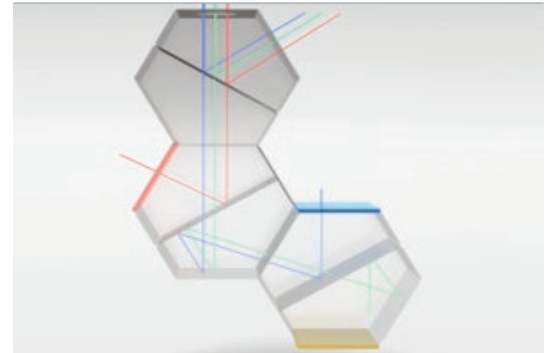

Benefits

- Optimized combination of high end coatings and assembly, due to wide technology portfolio
- Advanced miniaturization due to maximum clear apertures (edge-to-edge coating), ensures compact and efficient designs
- Expert engineering support for optimized system design in collaboration with our customers
- High temperature stability
- Flexibility in size and substrate material and shape

Applications

- Low light cameras
- Folded optics, like microscopy
- Multi beam scanning
- Topology mapping
- Point of Care health monitoring

Technical Data

Dimensions

Size	2 – 50 mm
x/y tolerances	+/- 0.005 mm
Angular tolerances	+/- 0.008°
Beam deviation	+/- 30''

Defects

ISO 10110-7	5/3x0.063
Patterns	<=2 μm pin dots

Typical Spectral Performance

Coating	customized UV; VIS; NIR
PBS extinction ratio	1000:1 @420 – 780 nm
Bandpass filters	CWL +/- 2 nm, FWHM +/- 2 nm
Edge steepness	90% to OD 6 in < 10 nm
Dichroic beamsplitter	cut-on/off tolerances ≤1%
Mirrors	dielectric: >99%, tunable λ metallic: >98%, VIS range

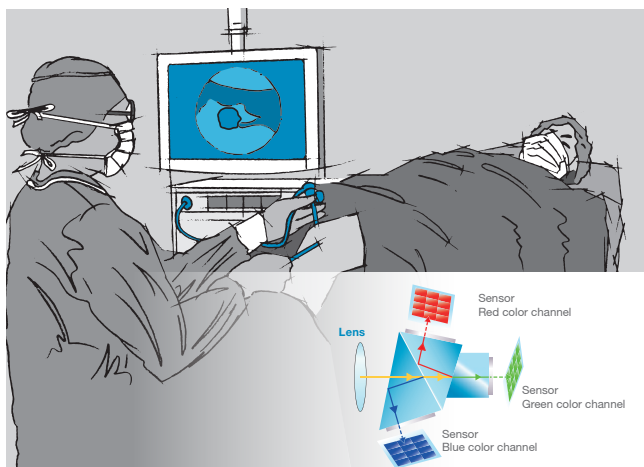

Applications: Endoscopic low light camera

Optics Balzers AG
Neugrüt 35
LI-9496 Balzers

Liechtenstein
T +423 388 9200
F +423 388 9390
info.mbo@materion.com
www.materion.com/balzersoptics

MBO 071PE (2410-1)

1/2

Subject to technical change without notice



Features

- Index matching bonding glue for high variety of substrates.
- Blackening with metallic or polymeric coatings, like black resist, black chrome, titanium > OD5 @ 2.5 μm
- High resolution patterning even on narrow areas. Feature size of 2.5 +/- 0.5 μm
- Combination with solderable coatings & soldering
- Single piece tracking



Color wheel coating & system assembly with electric motor

Capabilities

- Customized alignment tools for active and passive alignment. Ability to select most suitable alignment method
- Various metrology & characterization methodologies, e.g. collimators, beam deviation & wavefront measurement, ...
- Capability to create air gap between parts to make use of total internal reflection



High resolution aperture patterning of polarizing beamsplitter cube

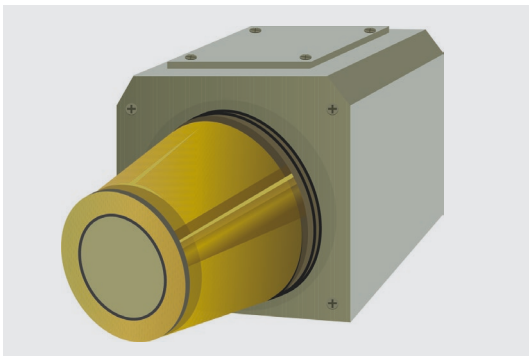

Hermetically sealed package, Coating and soldering



Frame mounting of coated glass

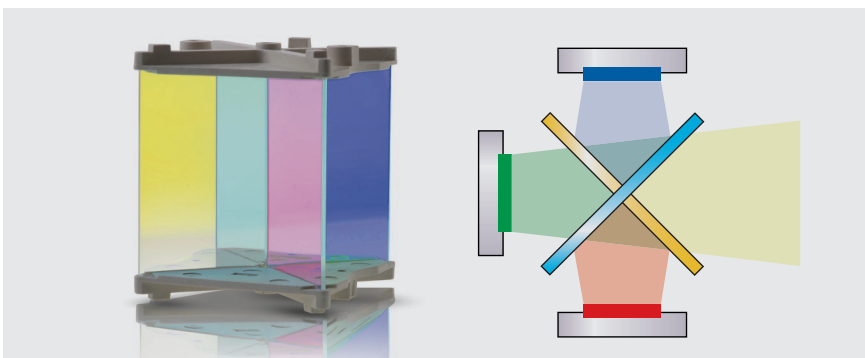

Coating & assembly of x-plate modules

Optics Balzers AG
Neugrüt 35
LI-9496 Balzers

Liechtenstein
T +423 388 9200
F +423 388 9390
info.mbo@materion.com
www.materion.com/balzersoptics